

Anchor clamp, PA-560 (3-8mm, 2 KN)

Product information:

Designed to anchor and tension ADSS cable in intermediate routes or dead end during outdoor overhead FTTx line constructions.

Applications: Outdoor FTTx fiber optic cable deployment

Features:

1. Easy installation, no require additional tools
2. Self-adjusting wedge, no damage to cable jacket
3. Material: UV resistant thermoplastic and stainless steel, durable
4. Open wire bail allow easy installation with pole brackets and hooks
5. Good environmental stability

Key parts: UV resistant plastic, stainless steel wire

Technical specification:

Product code	Cable size,mm	MBL,KN	Wire Bail length,mm
PA-560	Φ3-8	2.0	250



Drawings:

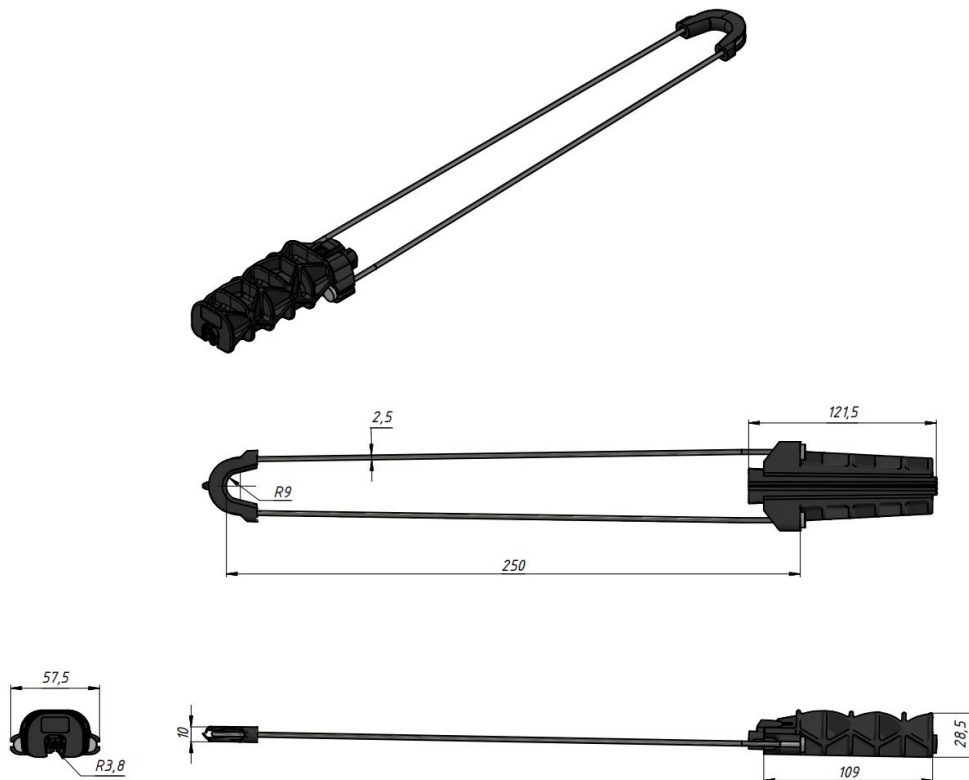

Application:

